

2 11 UNC
ASTM A307

3 1 - HEX NUT

4 1 - GALVANIZED
FLAT WASHER

NOTES:

1. MATERIAL - STEEL, ASTM F1554
(5/8" DIA. X 21" LONG BEFORE
BENDING).

2 FINISH - HOT DIP GALVANIZED,
PER ASTM A153 FULL LENGTH.
NUTS SHALL RUN FREE AFTER
PLATING.

3 RODS SHALL BE SUPPLIED WITH
GALVANIZED HEAVY HEX NUT,
ASTM A563, ASSEMBLED AFTER
ROD PLATING.

4 FLAT WASHER (SEE BELOW)
MATERIAL - 0.25" ASTM A36
FINISH - HOT DIP GALVANIZED.

5/8" DIA.

18"

3"

1/2" R

4 X 1/4" RAD.

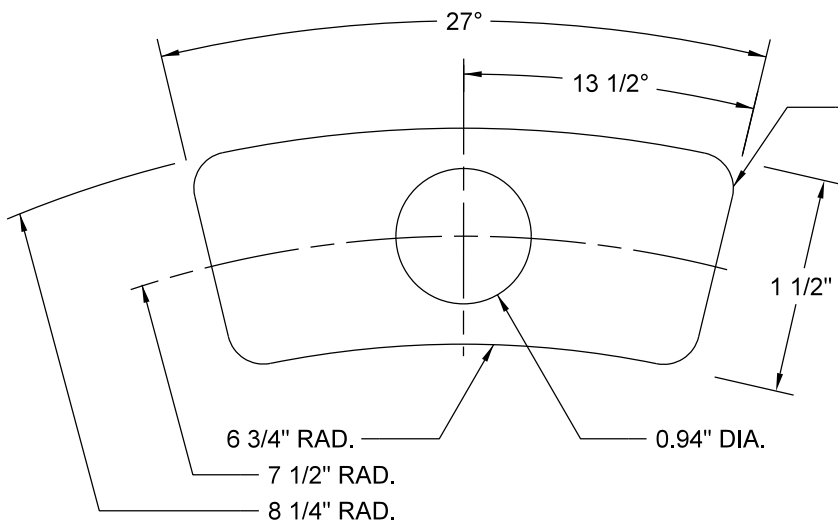

NO SCALE



DRW: EAV

DATE: 5/7/18

APP: DRP

DATE: 5/7/18

ANCHOR ROD - ST. LIGHT

5/8" X 18"

STANDARD
PLATE
NO.
TRAF-3140-R3