

NOTES:
 TYPE 3MS - 30B - 26MA - W/SA
 (1)(2)(3)(4) (5) (6)

1. NUMBER INDICATES LENGTH OF LUMINAIRE ARM.
2. MS INDICATES MINNEAPOLIS STYLE.
3. NUMBER INDICATES LUMINAIRE MOUNTING HEIGHT (30' TYPICAL).
4. LETTER INDICATES POLE TYPE.
5. NUMBER INDICATES SIGNAL MAST ARM LENGTH.
6. INDICATES REQUIREMENT FOR SIGNARM.
- ⑦ LUMINAIRE AS SPECIFIED.
- ⑧ VIDEO DETECTION HUB 1' FROM END OF MASTARM ON BOTTOM. EVP HUB 2' FROM END OF MASTARM AT TOP. 3/4" HALF COUPLINGS WITH PVC PLUG.
9. MATERIAL - HIGH STRENGTH LOW ALLOY STEEL 50,000 PSI MIN YIELD PER ASTM A572 OR A1011. BASE AND MOUNTING PLATES PER ASTM A36.
10. FINISH - PRIME PAINT EXTERIOR & FINISH PAINT EXTERIOR UPS MPLS BROWN
11. HEX HEAD BOLTS & NUTS (UNLESS SPECIFIED) ASTM A325 GALV A153

SEE MPLS. STD. PLATE TRAF-1170
 SEE MPLS. STD. PLATE TRAF-1074

NO SCALE

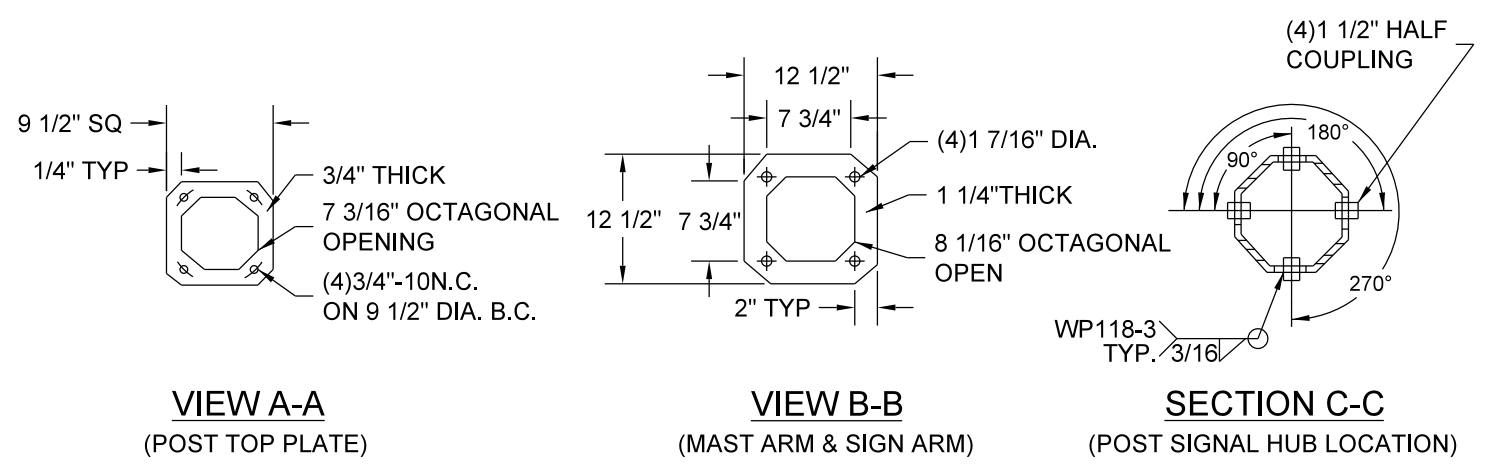

VIEW A-A
(POST TOP PLATE)

VIEW B-B
(MAST ARM & SIGN ARM)

SECTION C-C
(POST SIGNAL HUB LOCATION)

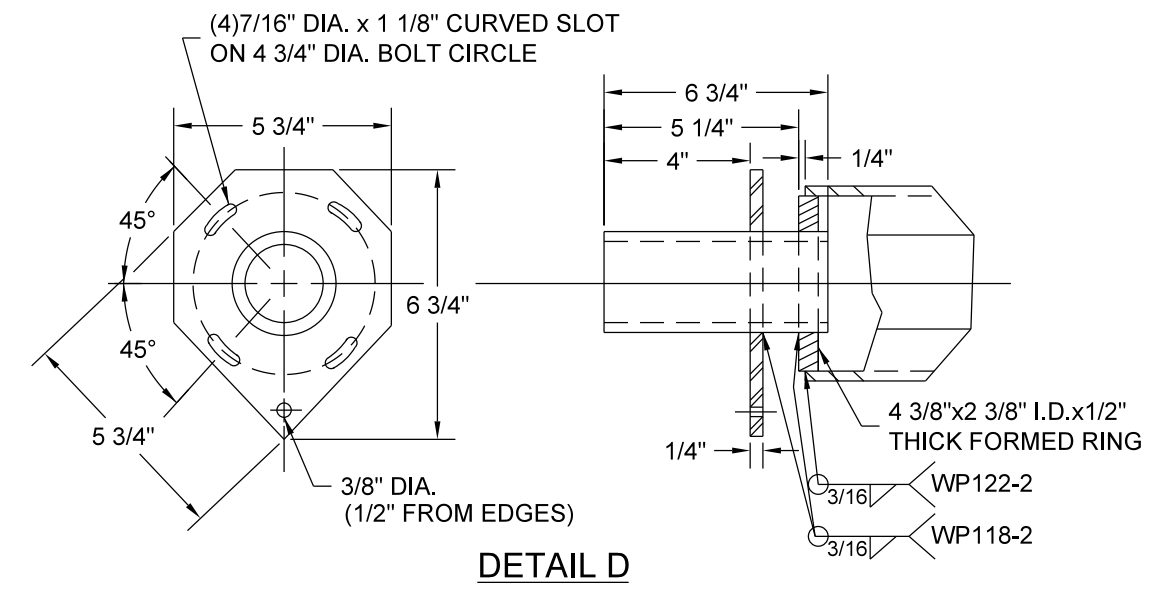

DETAIL D

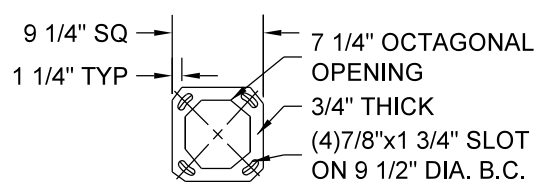

VIEW F-F

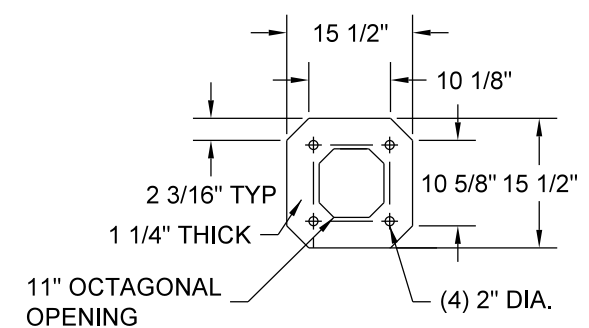

VIEW G-G
(POST BASE PLATE)

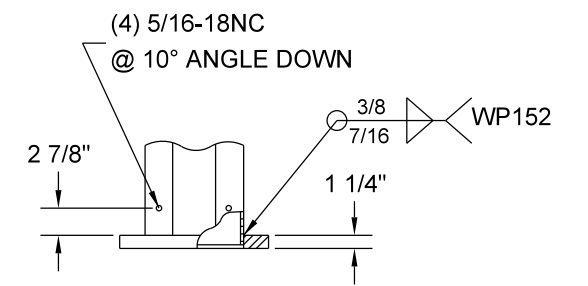

	DRW: EAV	DATE: 11/1/19	POLE - SIGNAL MASTARM 26'+ TYPE "B" REFERENCE PLATES: TRAF-1074, TRAF1170	STANDARD PLATE NO. TRAF-1231-R4
	APP: DRP	DATE: 11/1/19		