

SECTION A-A

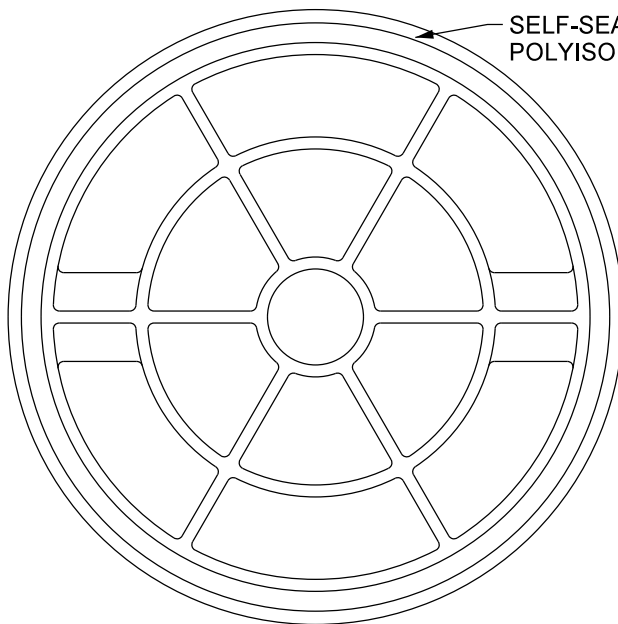

UNDER SIDE VIEW

SELF-SEALING GASKET (R 1/4")
POLYISOPRENE GASKET, 40 DUROMETER

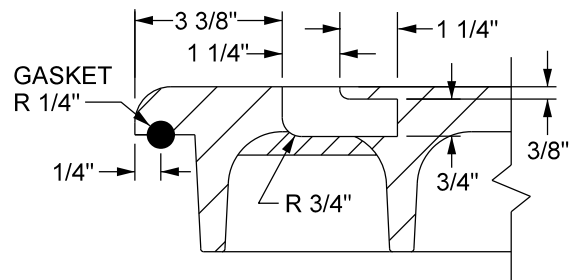

GASKET & PICK HOLE DETAIL

TO BE USED AT THE DISCRETION
OF THE CITY ENGINEER

NOTES:
WEIGHT = 204 LBS.
MATERIAL: GRAY IRON ASTM A-48, CLASS 358

MINNEAPOLIS CUSTOM
MNDOT SPEC. REF. 2506
NOT TO SCALE



DRW: CLK

DATE: 3/19

APP: KMM

DATE: 3/19

SELF-SEALING MANHOLE COVER

STANDARD
PLATE
NO.
SEWR-2001-R1