

DEWATERING DEVICE SHOULD BE PLACED AT THE LOW POINT OF THE AREA TO DRAIN

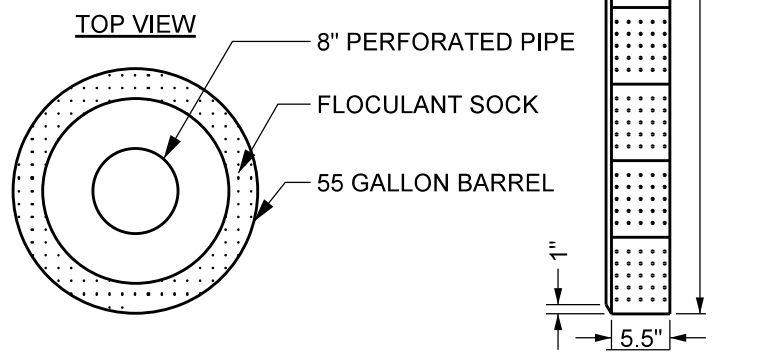

TYPICAL FLOCULANT SOCK

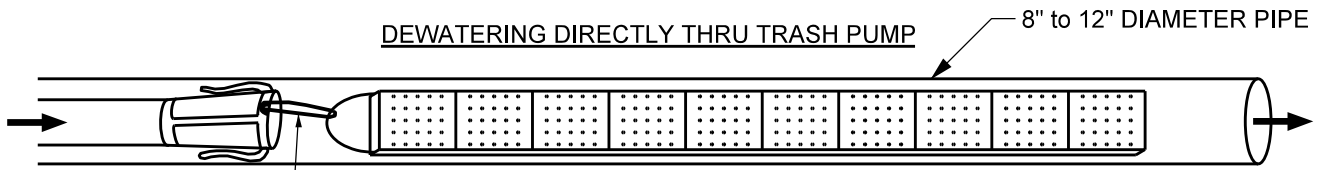

FLOW FROM TRASH PUMP DISCHARGE HOSE

SECURE FLOCULANT SOCK TO COUPLER CONNECT ON HOSE

MUST DISCHARGE WATER TO A SEDIMENT BASIN OR SEDIMENT TRAP. DO NOT DISCHARGE DIRECTLY TO A WATER BODY, OR A DIRECT CONVEYANCE TO A WATER OF THE STATE.

REFERENCES:
 MINNESOTA URBAN SMALL SITES
 BMP MANUAL pp.3-121 TO 3-129
 MNDOT EROSION CONTROL HANDBOOK

MINNEAPOLIS CUSTOM
 MNDOT SPEC. REF. 3898
 NOT TO SCALE



DRW: DCD	DATE: 1/05
APP: HRS	DATE: 4/07

DEWATERING -- TRASH PUMP

STANDARD
 PLATE
 NO.
 SEWR-8006