

STREET RESTORATION
 GRANULAR BORROW SPEC. MNDOT 3149.2 B1
 COMPACTION: MNDOT 2105.3 F1 - SPECIFY DENSITY METHOD 100% MAX. DENSITY
 MATCH EXISTING STREET BASE AND SURFACE

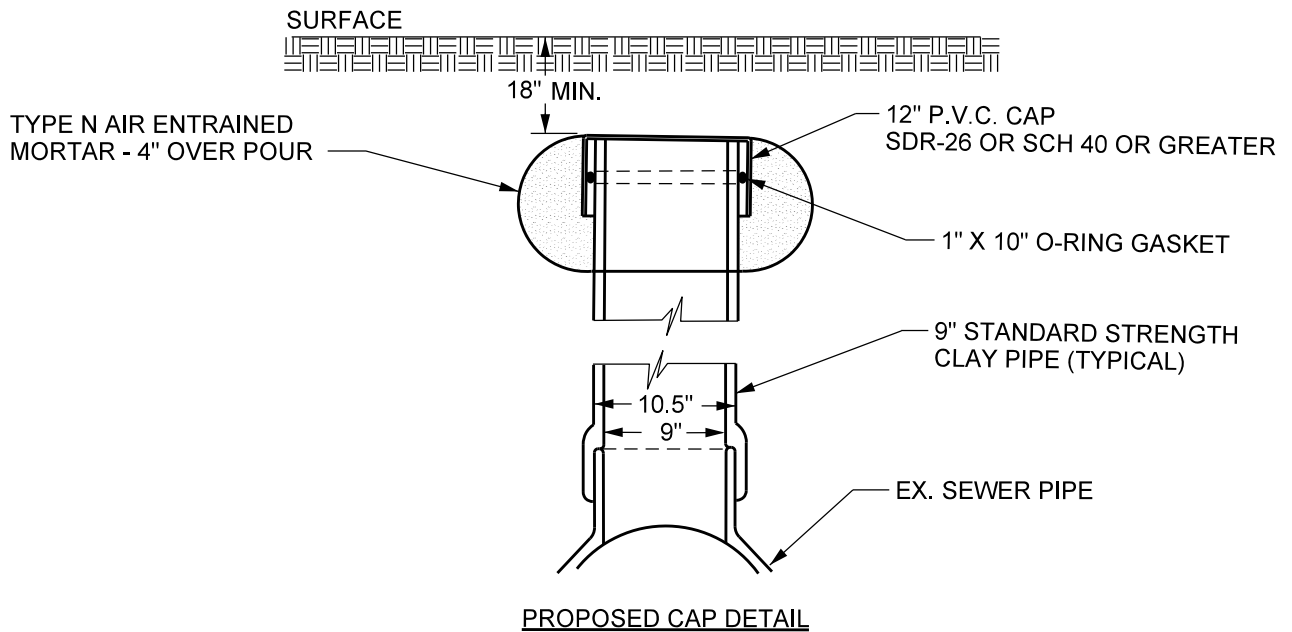

NOTES:
 REMOVE LAMP HOLE RING AND COVER.
 PLUG VERTICAL 9" CLAY PIPE LAMP HOLE
 WITH 12" PVC CAP AND RUBBER GASKET.
 BACK FILL AND TAMP OVER CAP PRIOR TO
 GRADING.
 GASKET TO MEET OR EXCEED ASTM C443 AND
 C923 NEOPRENE GASKET.

MINNEAPOLIS CUSTOM
 MNDOT SPEC. REF. 3245, 3251
 NOT TO SCALE



DRW: CXD

DATE: 3/03

APP: HRS

DATE: 12/06

LAMP HOLE CAP REMOVAL

STANDARD
 PLATE
 NO.
 SEWR-3002