

**NOTES:**

TYPE 3MS - 30A - 26MA - W/SA  
 (1)(2) (3)(4) (5) (6)

1. NUMBER INDICATES LENGTH OF LUMINAIRE ARM.
2. MS INDICATES MINNEAPOLIS STYLE.
3. NUMBER INDICATES LUMINAIRE MOUNTING HEIGHT (30' TYPICAL).
4. LETTER INDICATES POLE TYPE.
5. NUMBER INDICATES SIGNAL MAST ARM LENGTH.
6. INDICATES REQUIREMENT FOR SIGNARM.
- ⑦ LUMINAIRE AS SPECIFIED.
- ⑧ VIDEO DETECTION HUB 1' FROM END OF MASTARM ON BOTTOM.  
 EVP HUB 2' FROM END OF MASTARM ON TOP.  
 3/4" HALF COUPLINGS WITH PVC PLUGS.

NO SCALE

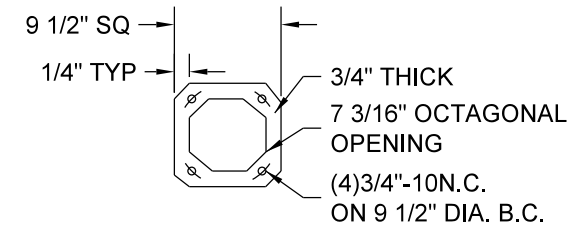

**VIEW A-A**

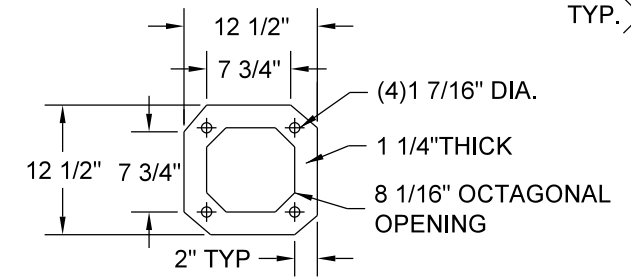

**VIEW B-B**  
 (MAST ARM & SIGN ARM)

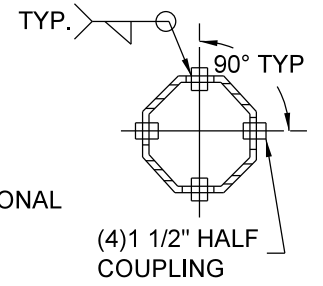

**SECTION C-C**

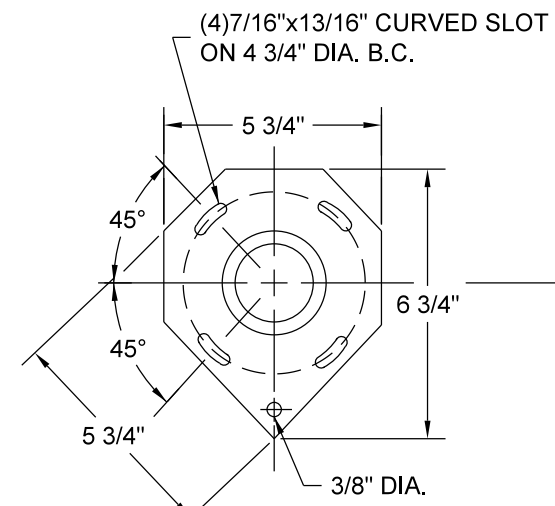

**DETAIL D**

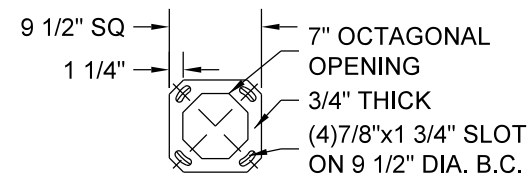
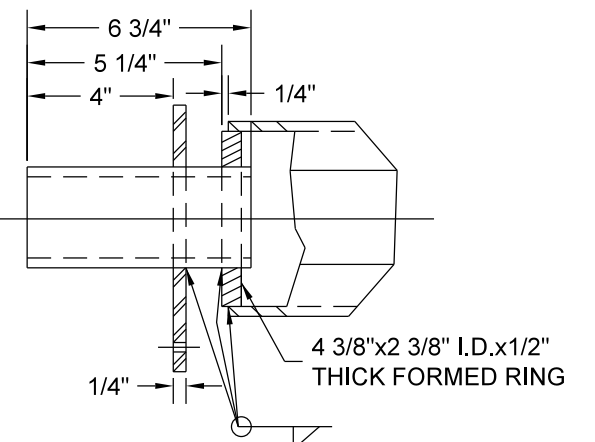

**VIEW F-F**

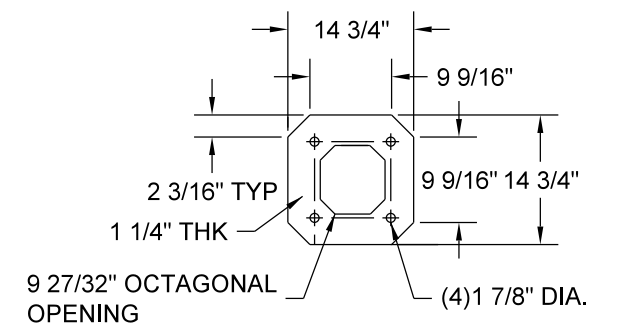

**VIEW G-G**

	DRW: EAV	DATE: 11/1/19	POLE - SIGNAL MASTARM 10'-26' TYPE "A" REFERENCE PLATES: TRAF-1072, TRAF1165	STANDARD PLATE NO. TRAF-1224-R4
	APP: DRP	DATE: 11/1/19		