

RODS ON 4 3/4" BOLT
CIRCLE AT 20" HEIGHT
INDICATED

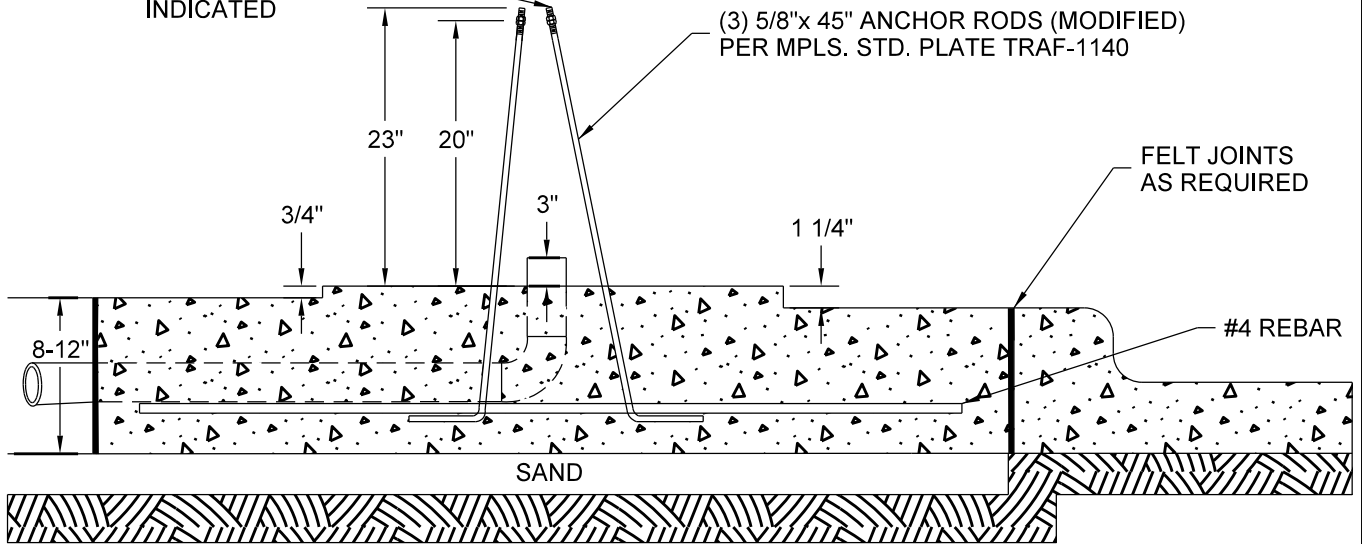

AREAWAY

NOTES:

ELECTRICAL DUCTS AS SPEC. (1)-3" NMC MAX. (3) #4 REBARS 42" LONG

ALL FOUNDATION LOCATIONS SHALL BE DETERMINED IN THE FIELD BY
TRAFFIC DIVISION AT TIME OF CONSTRUCTION.

NO SCALE



DRW: LPK

DATE: 1/1/11

APP: DRP

DATE: 1/1/11

FOUNDATION - SIGNAL
PEDESTAL SPREAD 48" X 48" X 8" - 12"
REFERENCE PLATE: TRAF-1140

STANDARD
PLATE
NO.
TRAF-1080