

2 3/4-10 UNC-2A
ASTM A307

3 2 - HEX NUTS,

4 1 - GALV. FLAT WASHER

NOTES:

1. MATERIAL - STEEL, ASTM A576
A151 - COLD DRAWN 1018
55,000 PSI MIN. YIELD
(3/4" DIA. X 24" LONG BEFORE
BENDING).

2 FINISH - HOT DIP GALVANIZED,
FULL LENGTH. NUTS SHALL
RUN FREE AFTER PLATING.

3 RODS SHALL BE SUPPLIED WITH
GALVANIZED HEAVY HEX NUTS,
ASTM A563, ASSEMBLED AFTER
ROD PLATING.

4 FLAT WASHER (SEE BELOW)
MATERIAL - 0.25" ASTM A36
FINISH - HOT DIP GALVANIZED.

3/4" DIA.

6"

20"

3"

3/4" R

4 X 1/4" RAD.

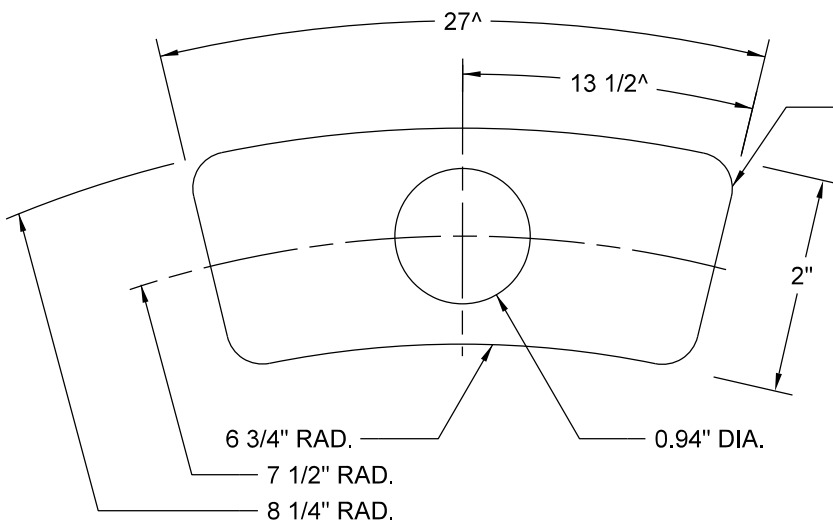

NO SCALE



DRW: LPK

DATE: 1/1/11

APP: DRP

DATE: 1/1/11

ANCHOR ROD - ST. LIGHT

3/4" X 20" W/WASHER

STANDARD
PLATE
NO.
TRAF-3135