

Footings – minimum size, depth, strength (2020 MN Residential Code R403.1.1; R403.1.4; R402.2 & R301.2)

The minimum width of footings, for a conventional one-story detached garage is 12 inches (305 mm); all exterior footings shall be placed at least 12 inches (305 mm) below the undisturbed ground surface; carport and garage floor slabs, in the state of Minnesota, shall be air entrained and must have a minimum compressive strength of 3,500 psi.

Foundation anchorage (2020 MN Residential Code R403.1.6)

Wood sole plates on monolithic slabs and all wood sill plates shall be anchored to the foundation with anchor bolts spaced a maximum of 6 feet (1829 mm) on center and shall be protected against decay and termites. Bolts shall be at least 1/2 inch (12.7 mm) in diameter and shall extend a minimum of 7 inches (178 mm) into concrete or grouted cells of concrete masonry units. A nut and washer shall be tightened on each bolt. There shall be a minimum of two bolts per plate section with one bolt located not more than 12 inches (305 mm) or less than 7 bolt diameters from each end of the plate section. All anchor bolts installed in masonry shall be grouted in place with at least 1 inch (25 mm) of grout between the bolt and the masonry.

Exceptions:

1. Foundation anchor straps spaced as required to provide equivalent anchorage to ½-inch diameter (12.7 mm) anchor bolts. When vertical reinforcement is required by other sections of this code, the foundation anchor straps shall align with the reinforcing.
2. Walls 24 inches (609.6 mm) total length or shorter connecting offset braced wall panels shall be anchored to the foundation with a minimum of one anchor bolt located in the center third of the plate section and shall be attached to adjacent braced wall panels according to Figure R602.10.5 at corners.
3. Walls 12 inches (304.8 mm) total length or shorter connecting offset braced wall panels shall be permitted to be connected to the foundation without anchor bolts. The wall shall be attached to adjacent braced wall panels according to Figure R602.10.5 at corners.

Unbalanced backfill (2020 MN Residential Code R404.1.3)

Walls supporting more than 48 inches (1219 mm) of unbalanced backfill that do not have permanent lateral support at the top or bottom, or walls that are subject to hydrostatic pressure from groundwater, shall be designed in accordance with accepted engineering practice.

Height above finished grade (2020 MN Residential Code R404.1.6 & R317.1)

Concrete and masonry foundation walls shall extend above the finished grade adjacent to the foundation a minimum of 4 inches (102 mm) where masonry veneer is used and a minimum of 6 inches (152 mm) elsewhere.

Concrete floors on ground (2020 MN Residential Code R506)

Concrete flooring on ground shall have a minimum thickness 3 1/2 inches (89 mm), maximum subgrade earth fill of 8 inches (203 mm) or sand/gravel of 24 inches (610 mm), base course of 4 inches (102 mm) graded with a maximum 2 inches (51 mm) aggregate.

Most detached garages are not required to be built on frost footing/foundation; however, this may depend on the grade or soil conditions of your property. The first two examples are most typical.

Unfinished Detached Garage (maximum 1000 square feet)

Floating Slab-On-Grade: Wall framing and plate lay directly on thickened perimeter footing.

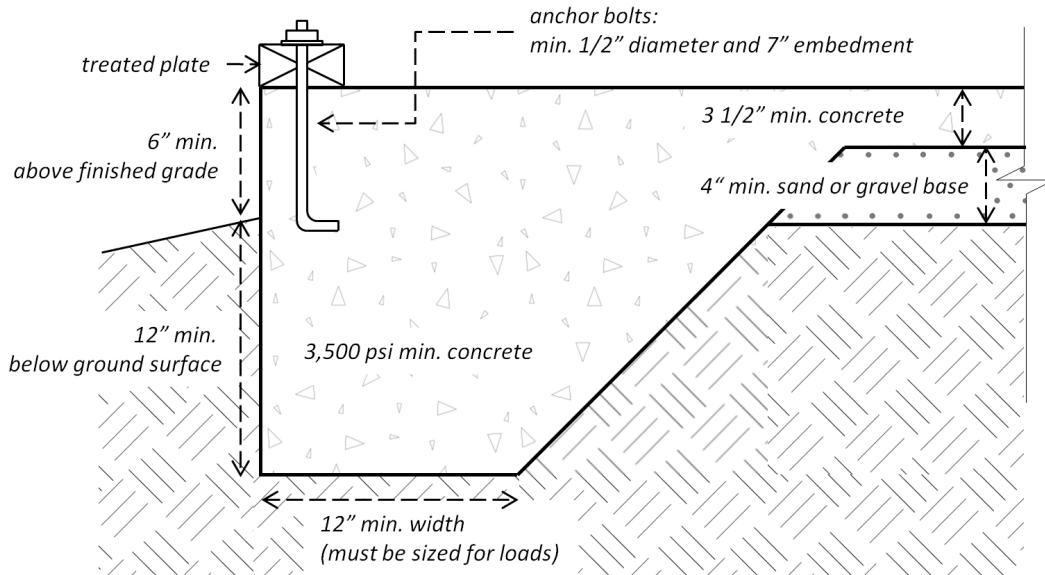

1 Course Masonry Foundation: Wall framing and plate sit on one course of masonry block on top of thickened perimeter footing.

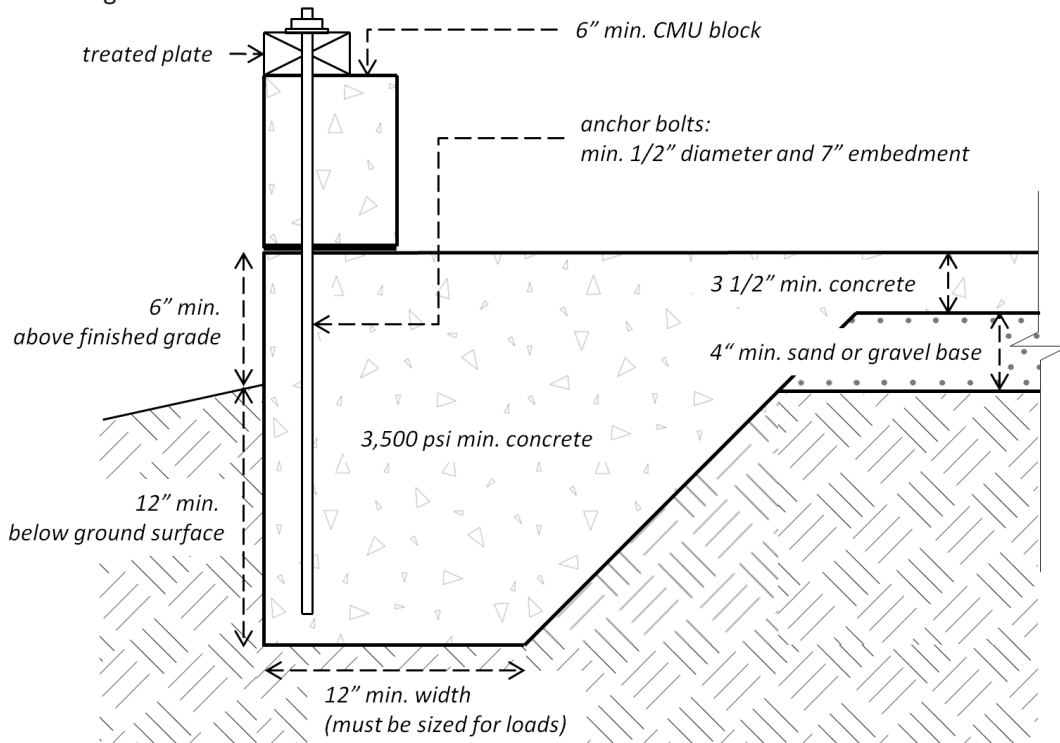

Habitable Two-Story Detached Garage

Course Masonry Foundation: Frost footings at 42" are always required when garage has second habitable story. (Foundation may also be poured.)

