

BASEMENT FINISH, 1 & 2 FAMILY DWELLINGS

Construction Code Services Division
Informational Bulletin

Revised June 2016

Any proposed basement finishing must comply with all of the following requirements. Submit 2 copies of plans showing compliance with these requirements to the Plan Review Section to obtain the required building permit. The requirements herein must be met in order for finished basement space to be considered habitable space as defined in the Minnesota State Building Code. If the requirements are not or cannot be met the space may be finished as non-habitable space.

General Basement Finish Requirements

Smoke Alarms Requirements

Per Section R314 of the IRC, see attached State of Minnesota guidelines for placement and use of smoke alarms.

R314 Alterations, repairs and additions.

When alterations, repairs or additions requiring a permit occur, or when one or more sleeping rooms are added or created in existing dwellings, the individual dwelling unit shall be equipped with smoke alarms located as required for new dwellings, the smoke alarms shall be interconnected and hard wired.

Exceptions:

1. Interconnection and hardwiring of smoke alarms in existing areas shall not be required to be hardwired where the alterations or repairs do not result in the removal of interior wall or ceiling finishes exposing the structure.
2. Work involving the exterior surfaces of dwellings, such as the replacement of roofing or siding are exempt from the requirements of this section.
3. Permits involving alterations or repairs to plumbing, electrical, and mechanical are exempt from the requirements of this section.
 - At least one detector shall be provided at each level, including the basement.
 - One detector in each sleeping room.
 - One detector in the hallway outside the sleeping rooms within the immediate vicinity of the bedrooms.
 - One each level including basements and habitable attics.
 - Hard wiring of smoke alarms in existing areas shall not be required where the alterations of repairs do not result in the removal of interior wall or ceiling finishes exposing the structure, unless there is an attic, crawl space or basement available which could provide access for hard

wiring without the removal of interior finishes. IRC 314.4 & HMC 244.915

Carbon Monoxide Alarms R315

R315.1 Carbon monoxide alarms.

Dwelling units shall have an approved and operational carbon monoxide alarm installed when one of the following conditions occur:

1. Fuel-fired appliances are installed; or
2. Have attached garages.

Installation. Carbon monoxide alarms shall be installed outside and not more than 10 feet from each separate sleeping area or bedroom. Alarms shall be installed on each level containing sleeping areas or bedrooms. (MN Stat. 299F.50)

Requirements for Bedroom(s)

1. Every bedroom must have an exterior door or at least one escape-rescue window meeting **all** of the following requirements:

5.7 ft² (821 in²) overall minimum net clear opening (measured in the open position – see illustration)

Exception: Grade floor openings shall have a minimum net clear opening of 5 square feet.

- 20” minimum net clear opening width
- 24” minimum net clear opening height
- Maximum height from finished floor to finished sill of escape-rescue window is 44”

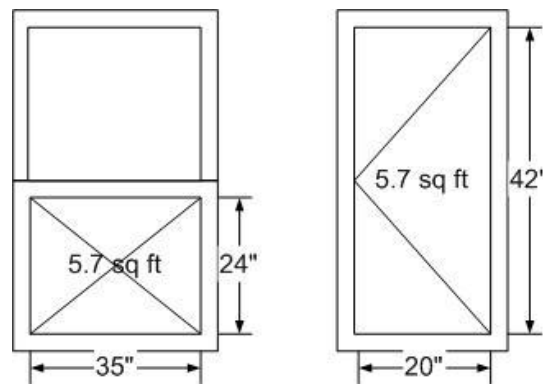

Bars, grilles, grates or similar devices may be installed on emergency escape windows, doors or window wells, provided

- The devices are equipped with approved release mechanisms which are open able from the inside without the use of a key or special knowledge or effort; and
 - The building is equipped with smoke detectors installed in accordance with Section 314.
 - Specific security grill systems require approval by the Department of Inspections prior to installation.
2. Escape and rescue windows with a finished sill height below the adjacent ground elevation shall have a window well. Window wells at escape or rescue windows shall comply with IRC R310:

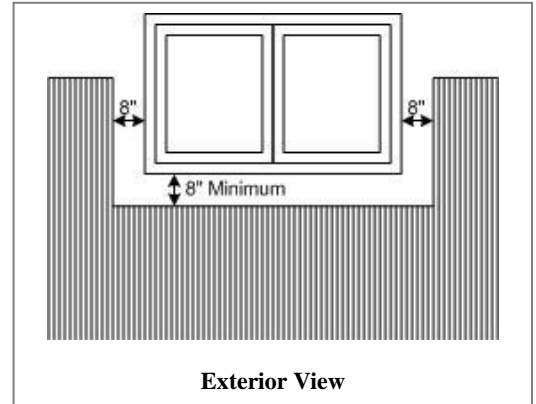
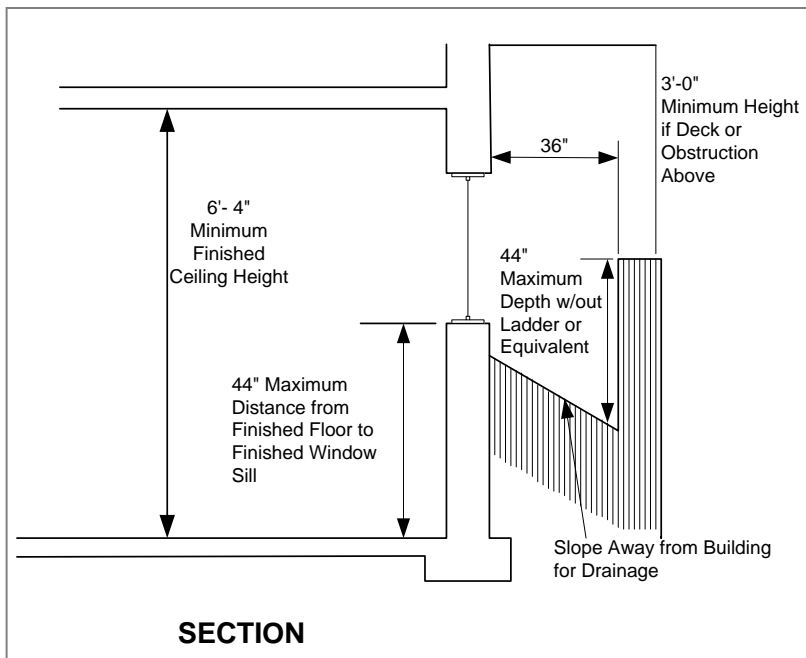

- The clear horizontal dimensions shall allow the window to be fully opened provide a minimum accessible net clear opening of 9 square feet with a minimum dimension of 36 inches.
 - Window wells with a vertical depth of more than 44 inches shall be equipped with an approved, permanently affixed ladder or stairs that are accessible with the window in the fully open position. The ladder or stairs shall not encroach into the required dimension of the window well by more than 6 inches.
 - If there is a deck or other obstruction above the window well, a 36 inches minimum height above exterior grade must be kept open.
 - Window well must extend at least 8" beyond each side of the window to provide a wood/earth separation and prevent rot per IRC Chapter 317.
 - Window wells require a minimum 2 foot setback (zoning) measured from the window well edge to a side or rear property line.
3. Smoke alarms and carbon monoxide (CO) alarms shall be installed per general basement finish requirements above. It shall be the owner's responsibility to maintain the alarms.
 1. Bedrooms, as well as the exit path to the stair or the exterior door, shall have a ceiling height of not less than 6 feet 4 inches measured from the finished floor to the lowest projection from the ceiling including beams, girders, ducts, or other obstructions. In existing structures where a 6 foot 4 inch ceiling height cannot be obtained, it is considered non-habitable space.
 2. Minimum size of bedroom is 70 square feet, with the least dimension being 7 feet.

3. Natural light and ventilation requirements: a minimum of 8% of the floor area of each bedroom must be provided in window glass area. Natural ventilation shall be through windows, doors, louvers or other approved openings to the outdoor air. Such openings shall be provided with ready access or shall otherwise be readily controllable by the building occupants. The minimum open able area to the outdoors shall be 4 percent of the floor area being ventilated.

For example, a bedroom having an overall floor area of 160 square feet must have:
 $160 \text{ sq.ft.} \times .08 = 12.8 \text{ sq.ft.}$ of glass area, **and** $160 \text{ sq. ft.} \times .04 = 6.4\text{ft}$ must be openable.

Natural ventilation exception: A mechanical ventilation system capable of providing 0.35 air change per hour in the room or a whole-house mechanical ventilation system is installed capable of supplying outdoor ventilation air of 15 cubic feet per minute per occupant on the basis of two occupants for the first bedroom and one occupant per each additional bedroom.

Natural light exception: artificial light capable of producing an average illumination of 6 foot-candles over the area of the room at a height of 30 inches above the floor level.

4. Required heating: Every dwelling unit shall be provided with heating facilities capable of maintaining a minimum room temperature of 68 degrees F at a point 3 feet above the floor and 2 feet from exterior walls in all habitable rooms (303.9).
5. Fuel-fired appliances shall not be located in or obtain combustion air from sleeping rooms, bathrooms or closets (303.3).
6. Stair Requirements:

Existing stairs (including stairways improved by increasing the floor opening size and reconstructing the stair) serving finished habitable space (bedroom, home occupation, or group family day care) in basements shall meet the following minimum:

Housing maintenance code requirements 244.960 and/or 2015 MN IRC 311.7:

- Stair width: 30” minimum
- Stair headroom: 6’4” minimum (R305.2.2)
- Stair rise: 8” maximum
- Handrail: 30” – 38” in height
- Stair run: 9” minimum
- Guardrail: 36” minimum height with intermediate openings less than 4” if new or alterations to existing required.

Newly constructed stairways must meet current 2015 MN IRC R311.7

ALL MATERIALS AVAILABLE IN ALTERNATIVE FORMATS. For more information please contact Minneapolis 311, if calling from outside the Minneapolis city limits, call (612) 673-3000.